

# MEDENUS



Gas Pressure Regulation



## Gas Pressure Regulator R 100 / R 100U

Product information



# EN



## Table of Contents

<b>Application, Characteristics, Technical Data</b>	<b>4</b>
Application	4
Characteristics	4
Types of models (Options)	4
Technical data	5
Design and function R 100	6
Design and function R 100 U	7
Accessories / Options	7
$K_G^*$ value and diaphragm assemblies	8
Diaphragm assembly setpoint spring table R 100 / R100 U	9
<b>Dimensions, Connection, and Weight</b>	<b>10</b>
Dimensions and weight	10
Dimensional drawing	11
Installation situation	11
Connection of the measuring lines and breather lines	12
<b>Order Data</b>	<b>14</b>
<b>Contact</b>	<b>16</b>
<b>Notes</b>	<b>18</b>



### ATTENTION

Observe the following publications in relation to installation, start-up and maintenance:  
 DVGW - work sheets G 491 and G 600  
 Operating and Maintenance Instructions R 100 / R 100 U

## List of abbreviations and formula symbols

AC	Accuracy class	$p_{ds\ o}$	Upper SSV response pressure	$W_{ds\ o}$	Upper spring adjustment range (SSV)
$AG_o$	Upper response pressure group	$p_{ds\ u}$	Lower SSV response pressure	$W_{ds\ u}$	Lower spring adjustment range (SSV)
$AG_u$	Lower response pressure group	$p_{f,max}$	Maximum closing pressure	$\Delta p$	Pressure difference from inlet pressure to outlet pressure
BV	Breather valve	PS	Maximum allowable pressure	$\Delta p_{wo}$	Min. re-engagement difference between upper response pressure and normal operating pressure
GPR	Gas pressure regulator	$p_u$	Inlet pressure	$\Delta p_{wu}$	Min. re-engagement difference between lower response pressure and normal operating pressure
HDS	High-pressure spindle	$Q_n$	Standard volumetric flow rate	$\rho_n$	Gas density
$K_G$	Valve flow rate coefficient	RE	Diaphragm assembly		
$p$	Pressure	RSD2	Throttle valve		
$p_d$	Outlet pressure	SSV	Safety shut-off valve		
$p_{df}$	SRV closing pressure	SRV	Safety relief valve		
$p_{do}$	SRV opening pressure	SG	Closing pressure group		
$p_{ds}$	Setpoint of the response pressure	$t_{Gas}$	Gas inlet temperature		
		VS	Valve seat		
		$w_d$	Outlet gas velocity		
		$w_u$	Inlet gas velocity		

\*)  $K_G$  value for natural gas

# Application, Characteristics, Technical Data

## Application

Gas pressure regulator (GDR), direct-acting (operating without auxiliary power), for systems acc. to DVGW work sheets G 491 (A) and G 600 (A) (TRGI)

Particularly suitable for dynamic regulation sections (e.g. gas fireplaces, natural gas supply systems, burner circuits, gas motor operation)

Can be used as an equipment component on gas consumption facilities as defined in Regulation (EU) 2016/426.

Can be used for the gases defined in DVGW work sheet G 260 / G 262 and neutral non-aggressive gases. (other gases on request)

## Characteristics

- Integral pressure-tight version (IS)
- Pilot pressure-compensated double-seat valve
- High flow rate capacity
- Open-air model

## Types of models (options) (see page 11)

- With throttle valve (RSD2) for the impulse line on the diaphragm assembly
- Oxygen model
- With FKM gaskets + stainless steel seat (e.g. for biogas applications)
- Coating with epoxy resin in RAL colors

Accuracy class AC and closing pressure group SG at the outlet pressure range $p_d$ , minimum pressure differential 100 mbar	AC	SG
8 mbar to 22 mbar	10	50
> 22 mbar to 1200 mbar	10	20

## Technical data

<b>Type</b>	R 100 / R 100 U	
<b>Model</b>	Integral pressure-tight (IS)	
<b>Max. allowable pressure PS</b>	8 bar	
<b>Max. inlet pressure <math>p_{u,max}</math></b>	R 100: 8 bar / R 100 U: 1.2 bar	
<b>Nominal width</b>	R 100: DN 50, DN 80, DN 100, DN 150, DN 200	
<b>Connection type</b>	DIN EN 1092 PN 16 flanges ASME - B16.5 flanges Class 150 RF	
<b>Material</b>	Housing / actuator housing/ Control device housing	Al cast alloy DIN EN 1706-AC-42100 ST6
<b>Corrosivity category</b>	DIN EN ISO 12944-2 C1 to C5-I C5-M	without additional coatings an epoxy resin coating is recommended
<b>Temperature range, Class 2</b> (operating/ambient temperature)	-20°C to +60°C	
<b>Closing pressure zone group</b>	SZ 10	
<b>Function, strength and tightness</b>	DIN EN 334	
<b>CE mark acc. to PED/ PIN number</b>	CE-0085-AQ0410	
<b>Ex protection</b>	The mechanical parts of the device do not have any potential ignition sources of their own and therefore do not fall within the scope of ATEX 95 (94/9/EC). Electrical components fitted to the device comply with the ATEX requirements.	

### Preferred installation position

The gas pressure regulators R100 shall be installed in the pipeline preferably in horizontal position. For all nominal widths, the direction of flow is indicated by an arrow on the housing.



Installation upside down only after consultation with Medenus GmbH

Note: Observe the following documents in relation to installation, start-up, and maintenance:

- DVGW - work sheets G 491 and G 600
- Operating and Maintenance Instructions R 100



# Application, Characteristics, Technical Data

## Design and function R 100

The spring-loaded gas pressure regulator R100 has the function of keeping the outlet pressure of a gaseous medium constant within allowable limit values, independently of the effect of interferences, such as changes in the inlet pressure and/or in the gas tap, in the connected regulation section on the outlet side. The gas pressure regulator is composed of the actuator housing and the "diaphragm assembly plus actuator" functional unit. The double-seat valve seat model is pre-pressure-compensated. The gas flows through the actuator housing in the direction of the arrow. The external measurement line port is used to pass the outlet pressure to be regulated to the bottom of the main diaphragm of the diaphragm assembly. It compares the actual value with the command variable preset by the force of the setpoint spring. The setpoint required in each case is set via the setting screw. Any deviation from the setpoint is transmitted by the screw spindle to the actuator, which is adjusted such that the actual value is adjusted to the setpoint. In case of zero tap, the actuator will close tight, causing the closing pressure to be established.

## Design and function R 100 U

The spring-loaded gas pressure regulator R 100U has the function of keeping the inlet pressure of a gaseous medium constant within allowable limit values, independently of the effect of interferences, such as changes in the outlet pressure, in the connected regulation section on the inlet side. The gas pressure regulator is composed of the actuator housing and the "diaphragm assembly plus actuator" functional unit. The double-seat valve seat model is pre-pressure-compensated. The gas flows through the actuator housing in the direction of the arrow. The external measurement line port is used to pass the inlet pressure to be regulated to the bottom of the main diaphragm of the diaphragm assembly. It compares the actual value with the command variable preset by the force of the setpoint spring. The setpoint required in each case is set via the setting screw. Any deviation from the setpoint is transmitted by the screw spindle to the actuator, which is adjusted such that the actual value is adjusted to the setpoint.

## Installation example

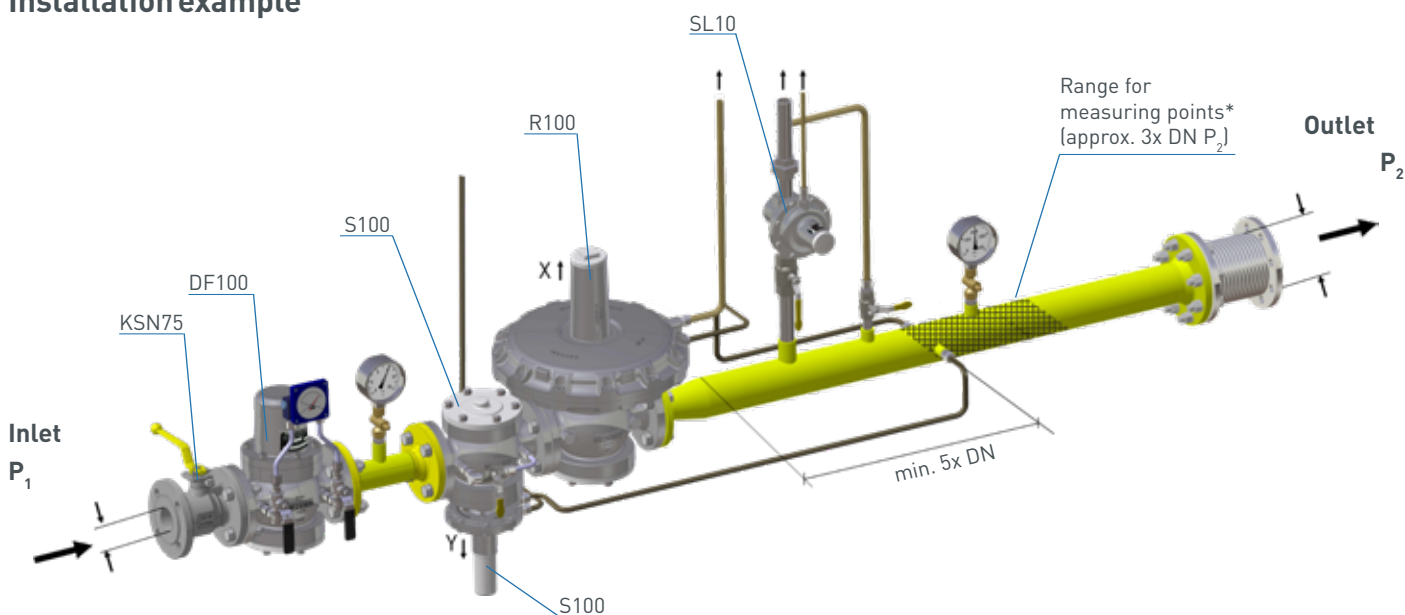

\*) Recommended max. velocity at the measurement line port 25 m/s

Sectional view

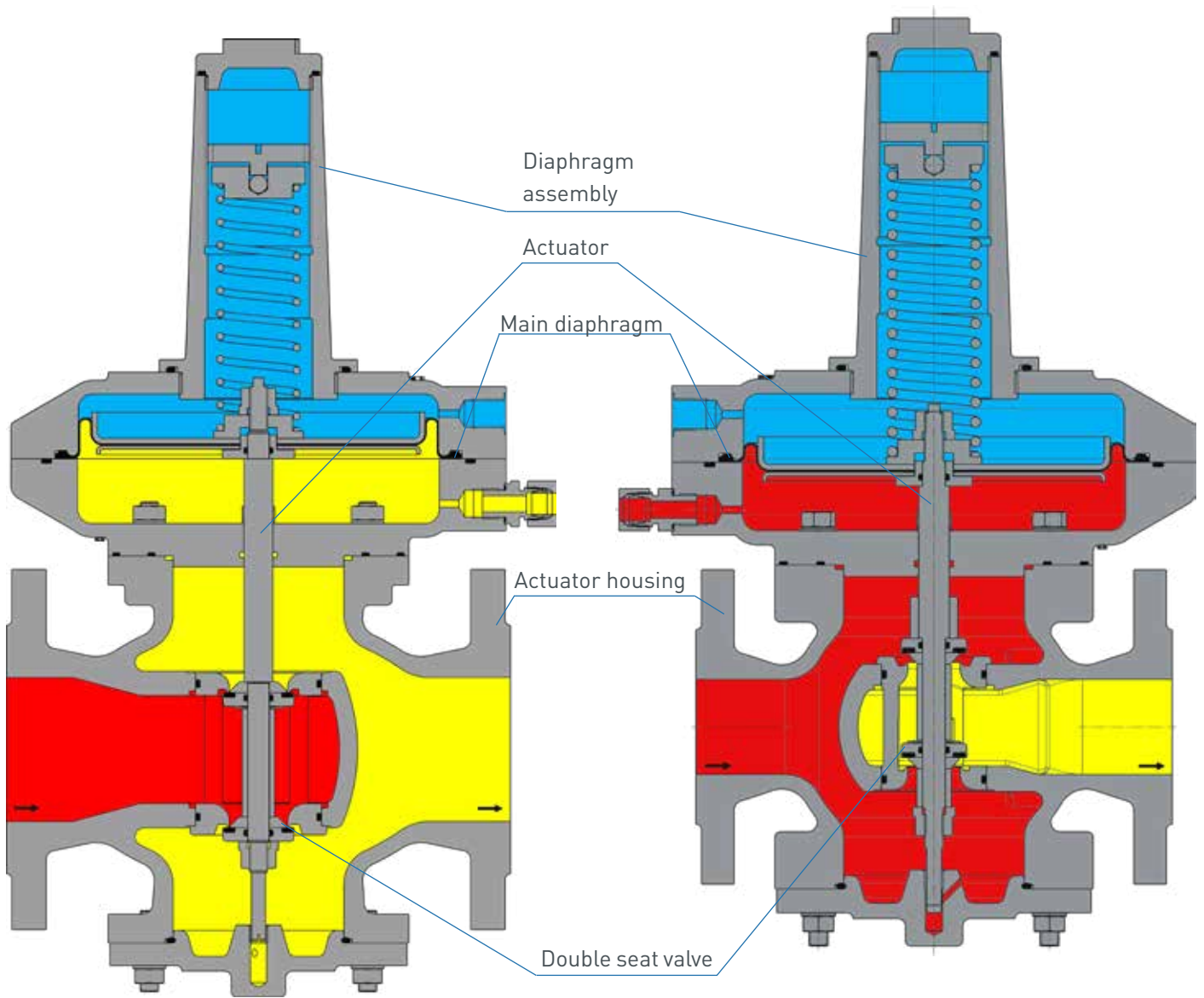

shown R 100

shown R 100 U

## K<sub>G</sub> value and diaphragm assemblies

(K<sub>G</sub> value for natural gas: d = 0.64 (ρ<sub>n</sub> = 0.83 kg/m<sup>3</sup>), t<sub>v</sub> = 15° C)

Nominal width	R 100					R 100 U				
	DN 50	DN 80	DN 100	DN 150	DN 200	DN 50	DN 80	DN 100	DN 150	DN 200
Diaphragm assembly Ø	160	160	160	275-2	275-2	160	160	160	275-2	275-2
Valve seat Ø	275	275	275	385	385	275	275	275	385	385
27.5 - 27.5 mm	800					1100				
32.5 - 32.5 mm		1500					1700			
42.5 - 42.5 mm			2400					3200		
45.0 - 50.0 mm		2500					3400			
60.0 - 65.0 mm			4700					6000		
65.0 - 65.0 mm				5200					7000	
90.0 - 90.0 mm					10000					11000
95.0 - 100.0 mm				12000					13500	
125.0 - 130.0 mm					20200					25000
Connection	DIN EN 1092 - PN16									

## RE - Diaphragm assembly

Regulator type Nominal width	Nominal width	Diaphragm assembly	Outlet pressure ranges [mbar]	Recommended use of the high-pressure screw spindle in the pressure range [mbar] (illustration with HDS on p. 11)
R100 / R100U	DN 50	RE 390	8 - 130	130 - 450
	DN 80	RE 275	130 - 450	450 - 1,100
	DN 100	RE 160	450 - 1,200	
	DN 150	RE 385	8 - 350	350 - 850
	DN 200	RE 275-2	350 - 850	850 - 1,200



## Diaphragm assembly setpoint spring table R 100 / R100 U

Spring data		Specific command range $W_{ds}$ [mbar]		
Spring no.	Color [RAL]	RE 160	RE 275	RE 390
FA 01	blank		-	8 - 10
FA 02	9006	-	-	9 - 12
FA 03	5015	-	-	11 - 13
FA 04	4002	-	-	12 - 15
FA 05	7037	-	-	14 - 19
FA 06	9005	-	-	18 - 24
FA 07	3020	-	-	23 - 32
FA 08	9010	-	-	31 - 45
FA 09	7016	450 - 600	130 - 156	42 - 64
FA 10	6010	510 - 800	141 - 225	59 - 94
FA 11	2002	760 - 1200	208 - 339	88 - 142
FA 12*	7035	-	293 - 484	124 - 203
FA 13*	5010	-	436 - 726	185 - 305
FA 14*	1028	-	607 - 1017	258 - 428
FA 15*	6018	-	699 - 1100	297 - 450

Spring data		Specific command range $W_{ds}$ [mbar]	
Spring no.	Color [RAL]	RE 275-2	RE 385
FB 701	6018	-	8 - 35
FB 702	9006	-	34 - 41
FB 703	5015	-	40 - 51
FB 704	4002	-	50 - 61
FB 705	7037	-	60 - 77
FB 706	9005	-	76 - 100
FB 707	3020	-	98 - 127
FB 708	9010	-	125 - 167
FB 709	7016	350 - 450	165 - 215
FB 710	6010	397 - 596	212 - 285
FB 711	2002	542 - 814	280 - 390
FB 712	7035	742 - 1078	385 - 520
FB 713*	5010	977 - 1200	515 - 671
FB 714*	1028	-	661 - 850

\* High-pressure spindle HDS required (illustration p. 11)

# Dimensions, Connection, and Weight

## Dimensional drawing

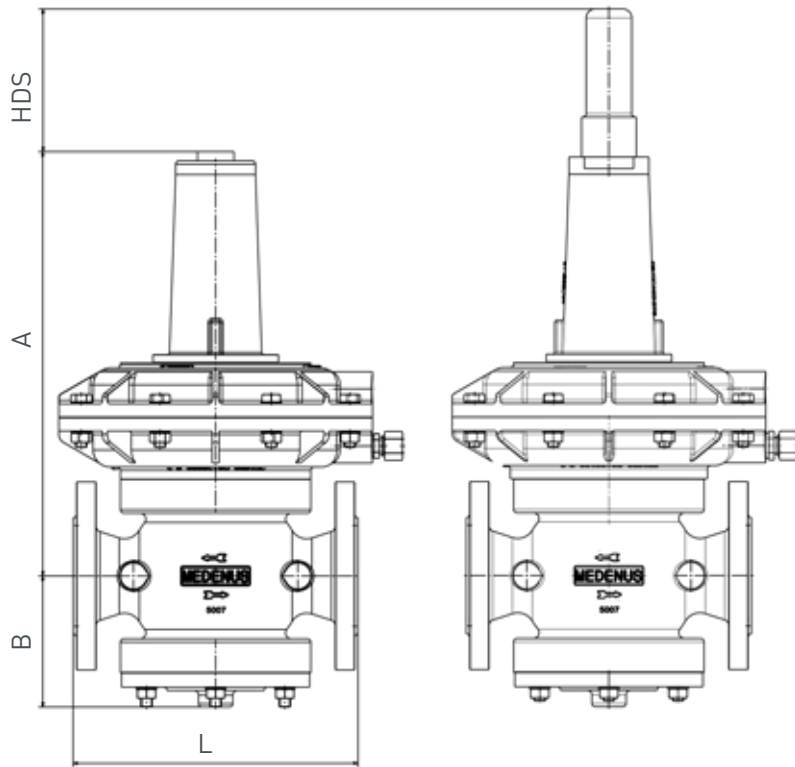

Dismounting dimensions for springs / HDS

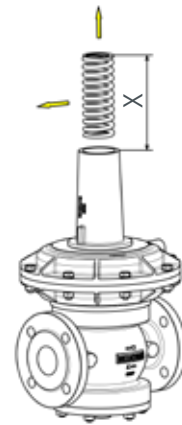

Safety diaphragm

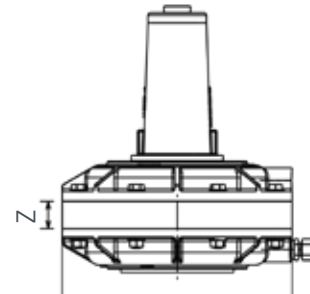

## Dimensions and weight

		R100 / R100 U					
		RE	DN 50	DN 80	DN 100	DN 150	DN 200
Dimensions	Nominal width	160	398	421	433	-	-
		275	372	395	407	694	724
		385/390	372	395	407	647	677
	HDS [mm]		125	125	125	205	205
	B [mm]		115	138	150	195	245
	L [mm]		250	280	300	380	420
	X [mm]		260	260	260	410	410
	Z [mm]		32.5	32.5	32.5	32.5	32.5
Weight [kg]		160	14	16	19	-	-
		275	17	19	22	62	60
		385/390	19	22	25	65	64
SM safety diaphragm weight [kg]		275	3	3	3	3.3	3.3
		385/390	5	5	5	6	6
	HDS weight [kg]		0.6	0.6	0.6	1.6	1.6
Connection		DIN EN 1092 - PN16					

Example: R100/050/390 with HDS and safety diaphragm

Weight (regulator + HDS + SM): 19 kg + 0.6 kg + 5 kg = 24.6 kg

Dimensions [A + HDS + SM]: 372 mm + 125 mm + 32.5 mm = 529.5 mm

## Types of Models / Options

### Safety diaphragm

In the model with safety diaphragm, the safety diaphragm is located above the main diaphragm. When the main diaphragm is damaged, the safety diaphragm makes contact with the top cover of the diaphragm assembly and limits any inadmissible escape of gas into the surrounding atmosphere to a maximum of 30l/h (air).

**(Option not available for hydrogen version H<sub>2</sub>)**



### RSD2 throttle valve

The RSD2 is a throttle valve which regulates the volume flow in the sensing/impulse line by means of a continuously adjustable cross-sectional reduction. The setting is made tool-free by means of a rotary knob and can be adjusted using a screw to be fixed. The throttle valve cannot be completely shut off, therefore a guaranteed minimum flow is ensured.



### High-pressure spindle HDS

The high pressure spindle (HDS) is used to adjust the control spring at high pressure. (See spring tables p. 9)



### Epoxy resin coating in RAL colors

To protect the gas pressure regulator from external influences, starting from a corrosivity category C5-M we recommend an epoxy resin coating.



### Types of models

Oxygen version O<sub>2</sub>

Hydrogen version H<sub>2</sub> (with helium leak test)

The Medenus gas pressure regulators are suitable for use with hydrogen as a medium up to a proportion of 100%. Further information can be found in the special edition (10/2019) of gwf Gas+Energie and on our homepage at ([www.medenus.de](http://www.medenus.de))



# Design

**Note** All calculated pressures are absolute pressures for natural gas. ( $p+1$  bar) The required  $K_G$  value for a gas pressure regulator is determined with the smallest inlet pressure or lowest pressure drop.

$p_u$  Inlet pressure (bar)  
 $p_d$  Outlet pressure (bar)  
 $Q_n$  Standard volumetric flow rate  $m^3/h$

## Calculation of the required $K_G$ value

$p_d / p_u > 0.5$   
 Value flow rate coefficient  $K_G$  at a subcritical pressure ratio  

$$K_G = Q_n / \sqrt{p_d \cdot (p_u - p_d)}$$

$p_d / p_u \leq 0.5$   
 Value flow rate coefficient  $K_G$  at a supercritical pressure ratio  

$$K_G = 2 \cdot Q_n / p_u$$

**Note** For spring-loaded devices, a capacity reserve of 10-20% is recommended in order to comply with the accuracies given.

The device is selected on the basis of its  $K_G$  value from the table of flow rate coefficients (page 8)

## Device selection

**Note** Closing pressure zone group: SZ 2.5

For the small load  $Q_{min}$  with SZ this yields 2.5:  $Q_{min} = 0.025 \cdot K_G \cdot p_{u\ max}$

Small load  $Q_{min}$  - When burner is started or at  $Q_{min}$  a  $K_G$  utilization level of at least 1% should be reached. Selection of the diaphragm assembly from the diaphragm assembly setpoint spring table (page 9)

Selection of the closing pressure group from the closing pressure group table (page 4)

$$P_{f\ max} = p_{ds} \cdot (1 + SG/100)$$

Selection of the SSVs from the SSV control device table (page 10)  
 Recommended upper SSV response pressure  $p_{dso} < 500\ mbar + p_{ds}$

**Example:** Overpressure Absolute pressure

$p_{u\ min}$  5.0 bar 6.0 bar  
 $p_{d\ min}$  0.5 bar 1.5 bar  
 $Q_{n\ min}$  2500  $m^3/h$

$1.5\ bar / 6\ bar = 0.25 < 0.5$   
 $\rightarrow$  Supercritical pressure ratio  
 $K_G = 2 \cdot 2500 / 6 = 833\ [m^3/(h \cdot bar)]$

### Selected device

Type R 100  
 DN - Nominal width 080  
 D - Nozzle V 32.5 - 32.5  
 $K_G$  value 1500  $m^3/(h \cdot bar)$

$$Q_{min} = 0.025 \cdot 833 \cdot 6 = 124.95\ m^3/h$$

Selected diaphragm assembly

RE - Diaphragm assembly 275  
 Setpoint spring FA11  
 ( $W_{ds}$  208 - 339)

AC 5/SG 10 (for RE 275 D - Nozzle 27.5)

Selected SSV

MD-R with FD 913 (285 - 460 mbar)  $AG_u$  10  
 set to  $P_{dso} = 375\ mbar$   
 and FE 901 (50 - 80 mbar)  $AG_u$  5

**Note** Standard setpoint springs SSV

(small ball lock)

MD FE 902 (12 - 24 mbar)  
 MD-R FE 901 (50 - 80 mbar)

(large ball lock)

MD FM 402 (35 - 115 mbar)  
 MD-R FM 400 (10 - 180 mbar)

Nominal width of input and output of pipeline according to the selected device: 80 mm  
 Selected widening of outlet pipeline: 200 mm

$$w_u = 380 \cdot 3000 / (80^2 \cdot 14) = 13\ m/s$$

$$w_d = 380 \cdot 3000 / (80^2 \cdot 1.25) = 143\ m/s$$

$$w_{impulse} = 380 \cdot 3000 / (200^2 \cdot 1.25) = 23\ m/s$$

## Determining the upper response pressure

Outlet pressure $P_d$ (mbar)	Upper response pressure $W_{dso}$ *
$\leq 200$	$P_d + 100\ mbar$
$> 200 - \leq 800$	$P_d \times 1.5$
$> 800 - \leq 1600$	$P_d \times 1.3$
$> 1600$	$P_d + 500\ mbar$

## Checking the gas velocities

$$w = 380 \cdot Q_n / (DN^2 \cdot p_{abs})$$

**Note** The factor 380 refers to an operating gas temperature from approx. 15°C to 20°C. For other temperatures, the velocity must be corrected as follows:  
 $w_{corr} = w \cdot (t_{gas} + 273.15) / 290$

Recommended max. gas velocity at the inlet flange:

50 - 70 m/s lower value for redirections upstream of the control valve, 20 m/s for upstream filters

Recommended max. gas velocity at the outlet flange:

100 - 200 m/s lower value to reduce noise emissions

Recommended max. gas velocity on impulse tap: 15 - 25 m/s

15 m/s max. value for outlet pressures below 100 mbar

The device selected in the example of nominal width DN 80 can be operated under these conditions.

\*) The upper response pressure is rounded up to full tens (e.g. 251 mbar  $\rightarrow$  260 mbar)







# Order Data

In every selection group, only one option can be selected in each case.

## Example:

Gas pressure regulator: R100/050/275/27.5-27.5/HDS/left/SM/RSD2/WAZ/So

Order selection	Designation	Order code:														
		R100	050	-	205	27.5-27.5	HDS	left	SM	RSD2	WAZ	So				
<b>Type</b>																
R 100	R 100	R100														
R 100 U	R 100 U															
<b>DN - Nominal width</b>	Table p. 8		050													
<b>Flange model</b>																
PN 16	-			-												
Class 150	C															
<b>RE - Diaphragm assembly</b>	Table p. 8				275											
<b>D - Nozzle (valve seat diameter)</b>	Table p. 8					27.5-27.5										
<b>High-pressure spindle</b>	Fig. p. 11															
without high-pressure spindle	-															
with high-pressure spindle	HDS							HDS								
<b>Direction of flow</b>																
Right (from left to right)	-															
Left (from right to left)	left								left							
<b>Additional unit, diaphragm assembly</b>	Fig. p. 11															
without additional unit, diaphragm assembly	-															
Safety diaphragm	SM									SM						
<b>Throttle valve</b>	Fig. p. 11															
without throttle valve	-															
with throttle valve	RSD2											RSD2				
<b>Acceptance test certificate to EN 10204/3.1</b>																
without acceptance test certificate	-															
with acceptance test certificate	WAZ												WAZ			
<b>Special model</b>	So															So

- Coating with epoxy resin in RAL colors
- Oxygen model
- Hydrogen model
- FKM gaskets + stainless steel seat



## Contact



Management  
ALEXANDER CHRISTIANI

Phone: +49 (0) 2761 / 82788-18  
Mail: a.christiani@medenus.de



Technical Inside Sales Department  
MINDAUGAS PECKAITIS

Phone: +49 (0) 2761 / 82788-23  
Mail: m.peckaitis@medenus.de



Head of Inside Sales Department  
MANUEL SCHEPP

Phone: +49 (0) 2761 / 82788-20  
Mobile phone: +49 (0) 170 / 6355309  
Mail: m.schepp@medenus.de



Inside Sales Department  
SEBASTIAN HUCKESTEIN

Phone: +49 (0) 2761 / 82788-11  
Mail: s.huckestein@medenus.de



Inside Sales Department  
STEFANIE MÜLLER

Phone: +49 (0) 2761 / 82788-13  
Mail: s.mueller@medenus.de



If you want to know more about solutions from MEDENUS for the gas industry, please contact your local contact person or go to our internet site at [www.medenus.de](http://www.medenus.de)

**Trade representation worldwide**  
[medenus.de/de/kontakt.html](http://medenus.de/de/kontakt.html)

**MEDENUS**  
Gas-Druckregeltechnik GmbH

Im Langen Feld 3  
D-57462 Olpe  
Phone: +49 (0)2761 82788-0  
Fax: +49 (0)2761 82788-9  
Mail: [info@medenus.de](mailto:info@medenus.de)  
**Internet: [www.medenus.de](http://www.medenus.de)**



## THE MEDENUS PLUS

### 10 reasons for good business relations

1. Consultancy expertise and quality standards developed over decades
2. Broad and proven standard range of feedback controllers
3. Modern, fast and efficient production for series products and for individual orders
4. Customer-specific design of pressure regulators and vacuum regulators and special designs
5. Guaranteed deadline compliance with a delivery deadline guarantee
6. Fast response time in all matters
7. Sufficiently large parts storage for production and spare parts
8. Customer-specific theory & practice training courses
9. Modular design right across the entire product range to facilitate optimized handling of spare parts
10. Made in Germany





**Flowstar (UK) Ltd**

Phone +44 (0)1482 601030  
WhatsApp +44 (0)7708 461097  
Wiltshire Road, Hull, HU4 6PA  
sales@flowstar.co.uk  
www.flowstar.co.uk

**EN**